

CS 501 D13/D15

SPARE PARTS LIST



NORTON
SAINT-GOBAIN®

clipper®

1 Spare parts list

Exploded View / Position	Article #	Designation Article	Type (*)
Q3404/ 1	00310327587	MAIN FRAME CS 501	S
Q3404/ 2	00310327591	ENGINE CONSOLE CS 501	S
Q3404/ 3	00310328746 00310002220	MOT.DIE. HATZ 1D90Z EL.START (CS 501 D15) MOT.DIE. HATZ 1D81Z EL.START (CS 501 D13)	S
Q3404/ 5	00310384715 00310384771	ENGINE PULLEY + HUB (CS 501 D15) ENGINE PULLEY + HUB (CS 501 D13)	S
Q3404/ 6	00310004303 00310327786	KEY 1/4"X1/4"X1"3/4 (CS 501 D15) KEY B8X6X45 (CS 501 D13)	S
Q3404/ 7	00310326419	BELT POLY-V 12PK915	W
Q3404/ 8	00310327819	OIL DRAIN HOSE M22X1.5	S
Q3404/ 9	00310327817	BELT GUARD HATZ CS 501	S
Q3404/ 10	00510004009	SPACER FOR BELT TENSIONER	S
Q3404/ 11	00310004283	BEARING 6200-LLU NTN	W
Q3404/ 12	00310002294	TENSIONING PULLEY	W
Q3404/ 13	00310327595	BRACKET FOR TENSIONING PULLEY CS 501	S
Q3404/ 14	00310327596	BLADE GUARD AXLE CS 501	S
Q3404/ 15	00310327597	BLADE GUARD CS 501	S
Q3404/ 16	00310327599	SPLASH GUARD CS 501	W
Q3404/ 17	00310327603	WATER NOZZLES CS 501	S
Q3404/ 18	00310004426	WATER SUPPLY TAP 1/2" F/F	W
Q3404/ 19	00310004181	BLADE GUARD NUT M16 GALVANIZED SW36	S
Q3404/ 20	00310002230	QUICK COUPLING 3/8"	W
Q3404/ 21	00310327605	WATER DISTRIBUTION BLADE GUARD CS 501	W
Q3404/ 22	00310002200	HOSE CONNECTOR R3/8"	W
Q3404/ 23	00510005781	RACCORD GEKA Nr 109A 3/8"MALE	W
Q3404/ 24	00310327606	TANK WATER DISTRIBUTION CS 501	W
Q3405/ 25	00310327637	DEPTH INDICATOR COMPL. CS 501	W
Q3405/ 26	00310326352	PARKING BRAKE HANDLE CS501	S
Q3405/ 27	00310327624	PARKING BRAKE CS 501	W
Q3405/ 28	00310327609	WHEEL HOOK + SPRING CS 501	S
Q3405/ 30	00310327818	DASH BOARD CS 501 D15	S
Q3405/ 31	00310331895	THROTTLE LEVER + SHEATHED CABLE CS501	S
Q3405/ 33	00310004915	KEY A8X7X40 DIN 6885	S
Q3405/ 34	00310004678	FRONT POINTER BEARING (SET OF 2)	S
Q3405/ 35	00310327629	ARM FOR GUIDE-A-CUT CS 501	S
Q3405/ 36	00310004622	WHEEL W/HARDWARE DIA.58	S
Q3405/ 37	00310004244	FRONT POINTER GUIDE	W
Q3405/ 38	00310384772	BLADE SHAFT PULLEY + HUB	W
Q3405/ 39	00310327630	BLADE SHAFT CS 501	S
Q3405/ 40	00310004295	BEARING BORE 30MM SKF SY30TF	S
Q3405/ 41	00310004506	KEY A8X7X20 DIN 6885	S
Q3405/ 42	00310005219	INNER COLLAR DIA. 108	S
Q3405/ 43	00310006563	SPACER 2 BLADES	S
Q3405/ 44	00510006025	GOUPILLE ELAST.DIN1481 10X65	S
Q3405/ 45	00310006562	LOOSE COLLAR 108 C99-CSB1	S
Q3405/ 46	00310004269	NUT 7/8" LEFT	S
Q3405/ 47	00310327632	PIVOTING FRAME CS 501	S
Q3405/ 48	00310004260	WHEEL	S
Q3405/ 49	00310004619	REAR AXLE BEARING (SET OF 2)	W
Q3405/ 50	00510005321	VIS DIN931 M20X120 T.H. Z	S
Q3405/ 51	00310005495	REAR WHEEL	S
Q3405/ 52	00510054671	SPACER REAR WHEEL CS501	W

Q3405/ 53	00310327634	DEPTH FEED DRIVING NUT CS 501	S
Q3405/ 54	00510054674	DEPTH FEED SPINDLE M20 CS501	W
Q3405/ 55	00310006555	STOP RING A20	W
Q3405/ 56	00310004343	BEARING FOR FEED TUBE FY20SD	S
Q3405/ 57	00310004966	HANDWHEEL NUT + BRAKE WASHER	S
Q3405/ 58	00310004840	HANDWHEEL D.240	S
Q3405/ 59	00310004363	KEY A6X6X28 DIN 6885	S
Q3405/ 60	00510007043	BUSH SPACER 28x22X22	S
Q3403/ 61	00310327639	WATER TANK SPLASH GUARD CPL. CS 501	S
Q3403/ 62	00310327674	REMOVABLE FRAME CS 501	W
Q3403/ 63	00310004800	LATCH & HARDWARE	S
Q3403/ 64	00310327675	TOOLBOX CS 501	S
Q3403/ 65	00310004053	FLAT WRENCH 19MM DIN894	S
Q3403/ 66	00310004177	FLAT WRENCH 36MM DIN894	S
Q3403/ 67	00310004229	FLAT WRENCH 17MM DIN894	S
Q3403/ 68	00310327676	REMOVABLE FRAME SUPPORT CS 501	S
Q3403/ 69	00510054731	PLOT PAULSTRA 2200 REF.530903 11	W
Q3403/ 70	00310327677	FRONT REMOVABLE FRAME SUPPORT CS 501	S
Q3404/ 71	00310327816	MOTOR HATZ SUPPORT CS 501	W
Q3404/ 72	00310327815	BATTERY STRAP CS 501	S
Q3404/ 73	00310004033	BATTERY 12V 44AH	W

(*): S = Spare part, W = Wear part

Wear parts are worn out through normal use of the machine. The wear period depends a lot on the intensity of use of the machine. Wear parts must be serviced, used and eventually changed following the indications of the manufacturer. Any wear due to normal use of the machine will not be considered as a case of warranty. Genuine Clipper replacement parts should always be used.

2 Exploded part drawings

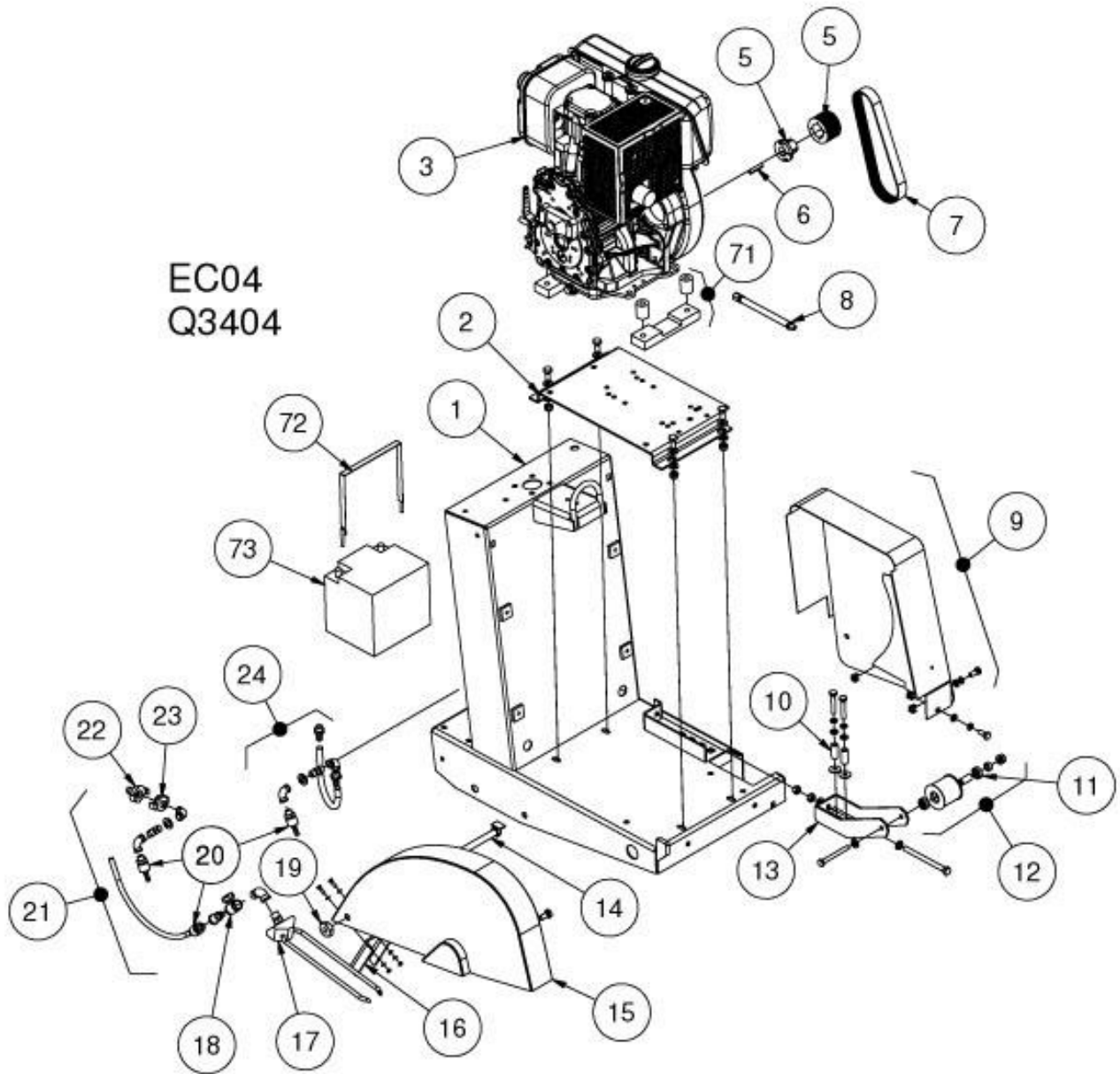

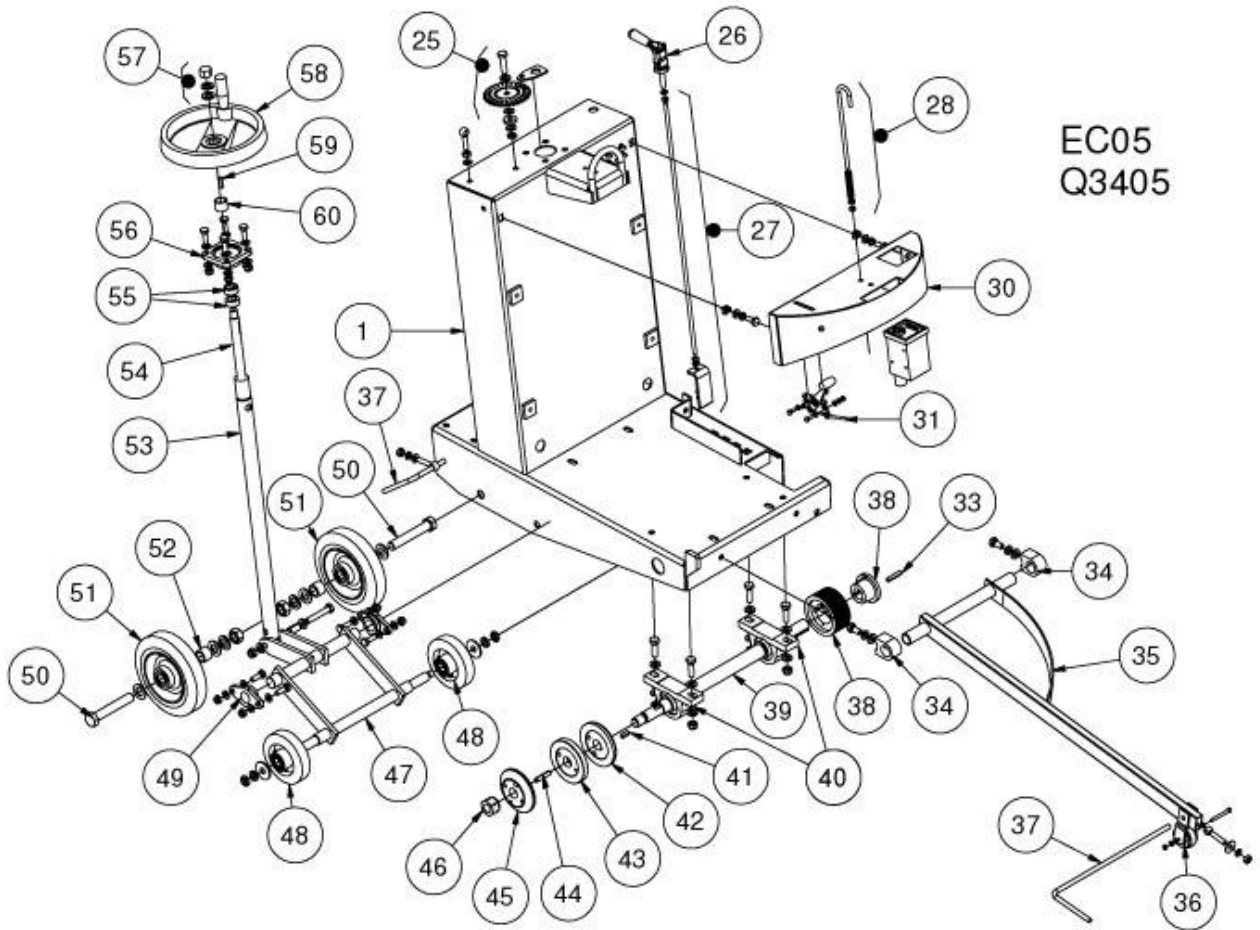

EC05
Q3405

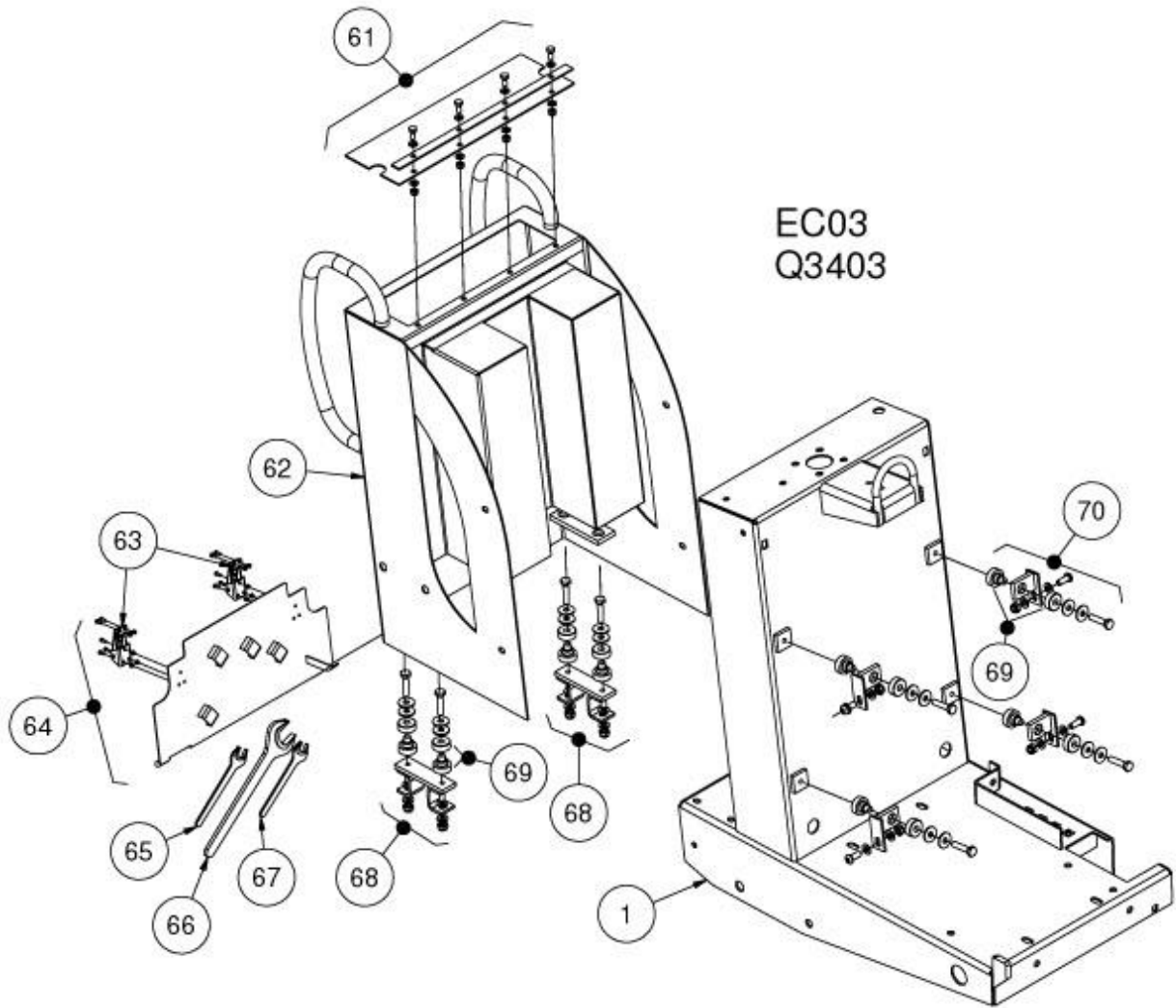

www.construction.norton.eu

Saint-Gobain Abrasives

190, Bd. J. F. Kennedy
L-4930 BASCHARAGE
LUXEMBOURG

Tel: ++352 50401-1

Fax: ++352 501633

e-mail: sales.nlx@saint-gobain.com